

Heat On Demand Ultra® Plus Induction Heating Activator Model ULT600

Heat On Demand Ultra® Plus offers an impressive combination of quality, performance, features, and efficiencies not offered by other induction meal delivery systems in its class. After a quick 12-second activation cycle, bases begin to thoroughly and consistently transfer, keeping food temperatures at or above 140°F (60°C) for 60+ minutes with a heated plate.¹



The prominent **LED status light** displays a different vibrant color at every stage.

HEAT ON DEMAND

Ultra **Plus**



60
MINUTES
HOLD TIME



12
SECONDS
CYCLE TIME

Heat On Demand Ultra Plus Benefits

- Short cycle time for fast tray assembly.
- Hot food for higher patient satisfaction scores.
- Time-tested design and component reliability.
- Simple operation for greater employee satisfaction.

Performance

- Used with a heated plate, Ultra® Plus maintains food temperatures at or above 140°F (60°C) for 60+ minutes.¹
- 12-second heating cycle activates up to 5 bases per minute.
- Bases stay cool to the touch and fit standard 9" entrée plates.

Construction

- Durable stainless steel countertop design.
- Solid-state electronic controls for enhanced reliability.
- Robust polymer centering guide for hassle-free base insertion and removal.
- Designed for use in commercial kitchens.

Standard Features

- **LED status light** signals cycle change (white / idle; red / heating; green / ready; yellow / error).
- **Compact, low-profile design.**
- **Automatic voltage calibration** adjusts activator settings for 208 to 240 volt power.²
- Cycle time not affected by voltage fluctuations.
- Error prevention logic eliminates the guesswork.
- Visual and audible indicators alert when the base is ready.
- Energy saving automatic shut-off.
- An automatic holding cycle keeps bases ready for use during breaks in the action.
- Internal fans keep electronics cool during heavy use.
- Base and activator diagnostics.
- Easy to remove washable air filter.
- Easy to clean.



Sustainability

- Energy-efficient induction technology.
- Automatic shut-off conserves electricity when not in use.

Heat On Demand Ultra® Plus

Induction Heating Activator

Model ULT600

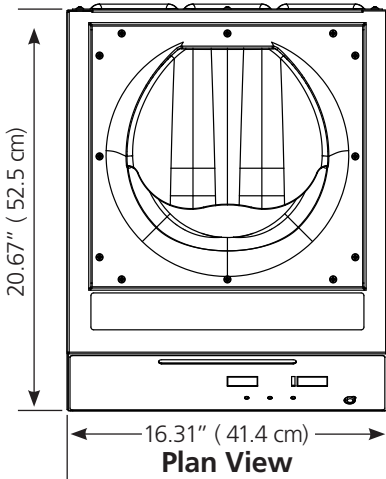

Ultra Plus System

Activates Ultra Bases (IHB24) which accommodate standard 9" (22.9 cm) dishware.

Visit aladdintemprite.com to see all Ultra base color options.

Heat On Demand® Ultra bases stay cool on the sides, so they're safe to handle without gloves or a base lifter, and they're safer for patients and residents too.

Use only with Aladdin Heat On Demand Ultra® bases.

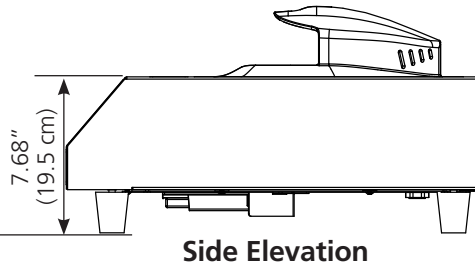
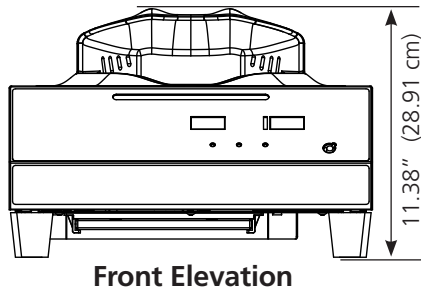

L15-20P NEMA
Twist-Lock Plug

Heat on Demand Ultra® Plus Technical Specifications

Model Number	Electrical ³	Cord Set/ Plug	Width	Depth	Height	Weight	Shipping Weight
ULT600	Volts: 208-240 Hertz: 50/60 Phase: Three Max amp draw: 15 Min. amp capacity: 20	L15-20P (4-wire) 5' (152.4 cm) cord with twist-lock plug	16.31" (41.4 cm)	20.67" (52.5 cm)	11.38" (28.91 cm)	34 lbs. (15.4 kg)	49 lbs. (22.2 kg)

¹ 11-oz. (311 grams) of food input at 165°F (74°C) with a 165°F (74°C) heated plate and Aladdin insulated dome.

² Auto-shift voltage feature automatically calibrates activator settings for 208-240 volt power. Unit should be operated on a 20-amp dedicated circuit.

Complies with CISPR 14/EN55014/EN6100.



FOR SERVICE AND WARRANTY INFORMATION

ULT600:
1 YEAR, Parts and Labor
Centering Guide:
2 YEARS, Parts

